

A CONDUCTION-COOLED TWO-KILOWATT AMPLIFIER

One of the major concerns when dealing with high power amplifiers is heat and how to reduce it. The usual method has been to use a large fan or

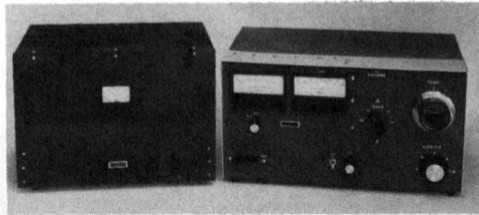

blower, but this solution is generally noisy. By using the principles of heat transfer, a noiseless amplifier can be made with the use of an adequate heat sink and conduction-cooled tubes.

The amplifier shown in the photographs and schematically in Fig. 1 uses a pair of recently designed 8873 conduction-cooled triode tubes. The circuit configuration is grounded grid and uses no tuned-input tank components. When properly adjusted, the amplifier is capable of IMD characteristics which are better than can be achieved by a

A 2-kW Amplifier

Top view of the 80-through 10-meter conduction-cooled amplifier. The chassis is $17 \times 12 \times 3$ inches ($43.2 \times 30.5 \times 7.6$ cm) and is totally enclosed in a shield. A separate partition was fabricated to prevent rf leakage through the meter holes in the front panel. An old National Radio Company vernier dial is used in conjunction with the plate tuning capacitor to provide ease of adjustment (especially on 10 meters). The position of the dial for each band is marked on the dial skirt with a black pen and india ink.

typical exciter, therefore the added complexity of band switching a tuned-input circuit was deemed unnecessary.

Construction

Building an amplifier such as this is often an exercise in adapting readily available components to a published circuit. For this reason, a blow-by-blow description of this phase of the project will not be given. An effort was made, however, to use parts which are available generally, and should the builder desire, this model could be copied verbatim.

The most difficult constructional problem is that of aligning the tube sockets correctly. It is imperative that the sockets be aligned so that when the tubes are mounted in place, the flat surfaces of the anodes fit smoothly and snugly against the thermal-link heat-transfer material. Any misalignment here could destroy the tubes (or tube) the first time full power is applied. The mounting holes for the tube sockets are enlarged to allow final positioning after the tubes are "socked" in place with the clamping hardware. Pressure must be applied to the anodes so that they are always snug against the thermal link. The hardware used to perform this function must be nonconducting material capable of withstanding as much as 250°C . The pressure bracket used here was fabricated from several Millen jack-bar strips (metal clips removed) mounted in back-to-back fashion. The entire assembly is held in place by means of a long piece of No. 10 threaded brass rod which passes through a small hole in the center of the heat sink. An attempt to give meaningful comments about how tight the tubes should be pressured to the copper and aluminum sink will not be given. Suffice it to say that the tubes should fit flat and snugly against the thermal hardware. The heat sink was purchased from Thermaloy and is connected to a 1/4-inch thick piece of ordinary copper plate. The total cost for the copper and the aluminum sink is somewhat more than the price of a good centrifugal blower (\$30) but the savings offered by not having to purchase special tube sockets and glass chimneys overcomes the cost differential.

Top view of the power supply built by WA1JZC showing the technique for mounting the filter-capacitor bank. The diodes are mounted on a printed-circuit board which is fastened to the rear of the cabinet with cone insulators and suitable hardware.

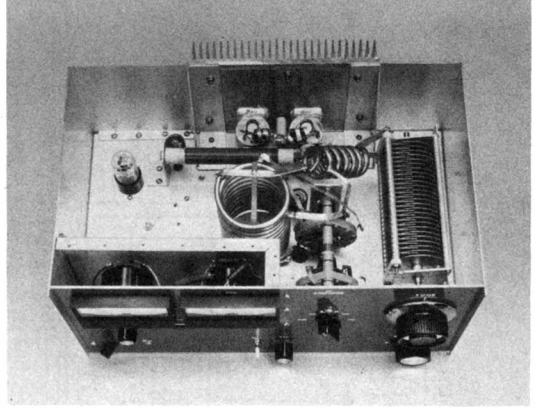

The power supply is built on a separate chassis because the plate transformer is bulky and cumbersome. A special transformer was designed for this amplifier by Hammond Transformer Co. Ltd., of Guelph, Ont. Canada. The transformer contains two windings, one is for the plate supply to be used in a voltage-doubler circuit and the other is for the tube filaments. The power supply produces 2200 volts under a load of 500mA, and is rated for 2000 watts. The Hammond part number is given in Fig. 1. All of the interconnections for power-supply control and the operating voltages needed by the amplifier are carried by a seven-conductor cable. This excludes the B plus, however, which is connected between the units by means of a piece of test-probe wire (5-kV rating) with Millen high-voltage connectors mounted at both ends. The seven-conductor cable is made from several pieces of two-conductor household wire (No. 10) available at most hardware stores. Since the main power switch is mounted on the front panel of the amplifier, the power supply may be placed in some remote position, out of the way from the operator (not a bad idea!). A high-voltage meter was included with the power supply so that it could be used with other amplifiers. It serves no purpose with this system. The main amplifier deck has provisions for monitoring the plate voltage.

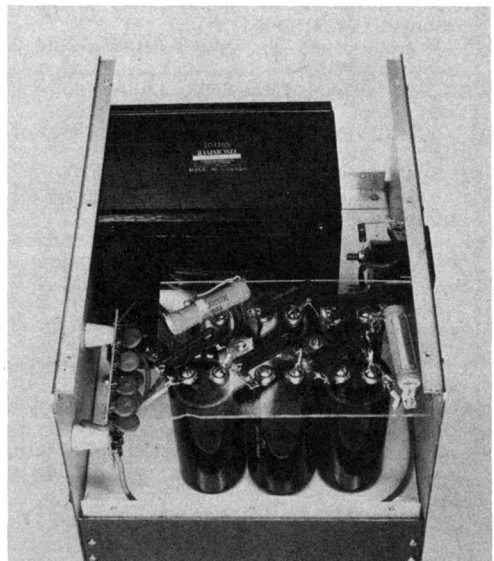

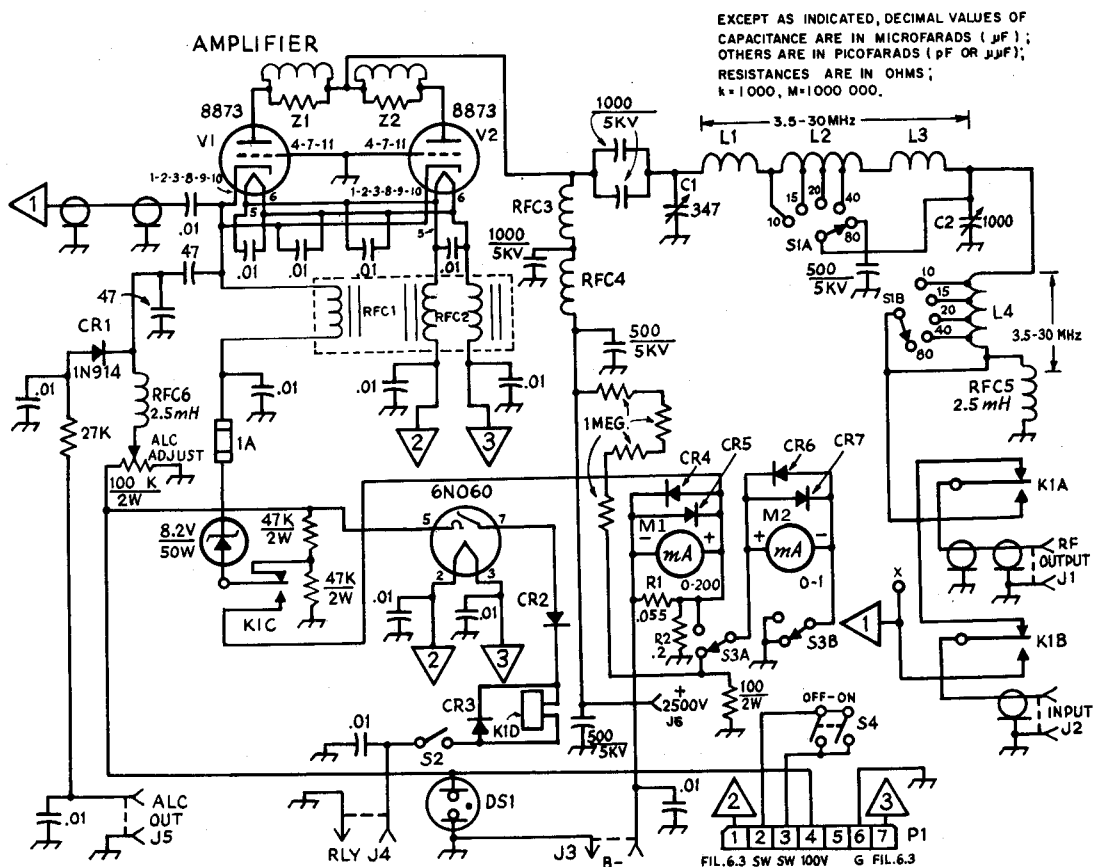
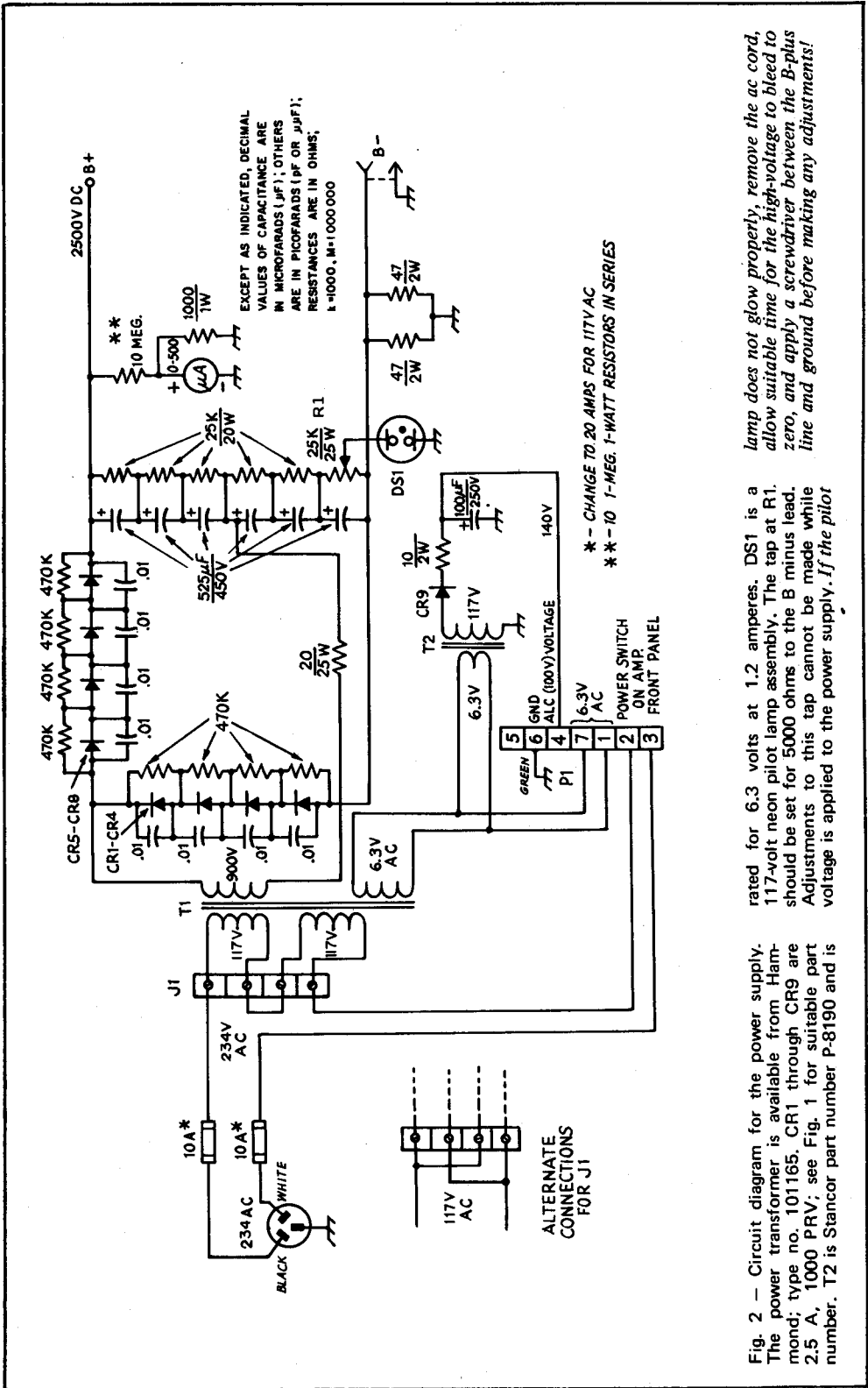

Fig. 1 - Circuit diagram for the 8873 conduction-cooled amplifier. Component designations not listed below are for text reference. RFC1 and RFC2 are wound on the same ferrite rod in the same direction; three wires are wound together (Amidon MU-125 kit). Tube sockets for V1 and V2 are E.F. Johnson 124-0311-100. The thermal links are available from Eimac with the tubes. The heat sink is part number 2559-080-A000 from Astrodyne Inc., 353 Middlesex Ave., Wilmington, MA 01887, and costs approximately \$20.

- C1 - Transmitting air variable, 347 pF (E.F. Johnson 154-0010-001).
 C2 - Transmitting air variable, 1000 pF (E.F. Johnson 154-30).
 CR2-CR7, incl. - 1000 PRV, 2.5 A (Motorola HEP170).
 J1 - SO-239 chassis mounted coaxial connector.
 J3, J4, J5 - Phono jack, panel mount.
 J6 - High-voltage connection (Millen 37001).
 K1 - Enclosed, three-pole relay, 110-volt dc coil (Potter and Brumfield KUP14D15).
 L1 - 4-3/4 turns of 1/4-inch copper tubing, 1-3/4-inch inside diameter, 2-1/4 inches long.
 L2 - 12-1/2 turns, 1/4-inch copper tubing, 2-3/4-inch inside diameter, tap at one turn from connection point with L1, 2-1/2 inches for 20 meters, 7-3/4 turns for 40 meters.
 L3 - 11-1/2 turns, 2-inch diameter, 6 tpi (Barker and Williamson 3025).
 L4 - 10 turns, 2-inch diameter, 6 tpi, with taps at 3 turns for 10 meters, 3-1/2 turns for 15 meters, 4-3/4 turns for 20 meters, 6-3/4 turns for 40 meters; all taps made from junction of

- L3 (Barker and Williamson 3025).
 M1 - 200 mA full scale, 0.5-ohm internal resistance (Simpson Electric Designer Series Model 523).
 M2 - 1 mA full scale, 43 ohms internal resistance (Simpson Electric, same series as M1).
 R1 - Meter shunt, .05555 ohms constructed from 3.375 feet of No. 22 enam. wire wound over the body of any 2-watt resistor higher than 100 ohms in value.
 R2 - Meter shunt, 0.2 ohms made from five 1-ohm, 1-watt resistors connected in parallel.
 RFC1, RFC5, RFC6 - 2.5 mH (Millen 34300-2500).
 RFC3 - Rf choke (Barker and Williamson Model 800 with 10 turns removed from the bottom end).
 RFC4 - 22 μH (Millen 34300).
 S1 - High-voltage band-selector style, double pole, six position (James Millen 51001 style).
 Z1, Z2 - 2 turns 3/8-inch-wide copper strap wound over three 100-ohm, 2-watt resistors connected in parallel.



lamp does not glow properly, remove the ac cord, allow suitable time for the high-voltage to bleed to zero, and apply a screwdriver between the B-plus line and ground before making any adjustments!

rated for 6.3 volts at 1.2 amperes. DS1 is a 117-volt neon pilot lamp assembly. The tap at R1 should be set for 5000 ohms to the B minus lead. Adjustments to this tap cannot be made while voltage is applied to the power supply. If the pilot

Fig. 2 - Circuit diagram for the power supply. The power transformer is available from Hammond; type no. 101165. CR1 through CR8 are 2.5 A, 1000 PRV; see Fig. 1 for suitable part number. T2 is Stancor part number P-8190 and is

A conventional household light switch may be used for S4. If the switch is to be mounted horizontally, be sure to use a contactor device and not a mercury type (which operates in a vertical position only). A double-pole switch was used with both poles connected in parallel. The rating is 220 V at 10 A per section.

The RF Deck

The two sections of the pi-L network are isolated from each other by placing one of them under the chassis. Although not shown in the photograph, a shield was added to prevent rf energy from entering the control section underneath the chassis. The shield divides the chassis between the tube sockets and the inductors. The loading capacitor is mounted directly beneath the plate-tuning capacitor. This scheme provides an excellent mechanical arrangement as well as a neat front-panel layout.

The 8873s require a 60-second warmup time, and accordingly, a one-minute time-delay circuit is included in the design. The amplifier IN/OUT switch is independent of the main power switch and the time delay. Once the delay circuit "times out," the amplifier may be placed in or out of the line to the antenna, whenever desired. A safety problem exists here: there is no large blower

running, and there are no brightly illuminated tubes to warn the operator that the amplifier is turned on. Except for the pilot lamp on the front panel, one might be fooled into believing the amplifier is turned off! And if the pilot lamp should burn out, there is *absolutely* no way to tell if the power is turned on (with the resultant high voltage at the anodes of the 8873s). *Beware!*

Operation

Tuning a pi-L-output circuit is somewhat different than tuning a conventional pi-network because the grid current should be monitored closely. Grid current depends on two items, drive power and amplifier loading. The procedure found to be most effective is to tune for maximum power output with the loading sufficiently heavy to keep the grid current below the maximum level while adjusting the drive power for the proper amount of plate current. The plate current for cw operation should be 450 mA and approximately 900 mA under single-tone tuning conditions for ssb. This presents a problem since it is not legal to operate under single-tone tuning conditions for ssb. Sixty watts of drive power will provide full input levels. For use with high-power excitors, see *QST* for October, 1973.